

Ritespec500

CLAMSHELL BUCKET

FOR LORRY LOADER CRANES

MADE
IN
ITALY



The Ritespec 500 Clamshell Bucket is a premium quality attachment designed and built for PCM Handling, especially to suit the demands of the UK market , by one of Europe's leading attachment manufacturers.

The Ritespec 500 is intended primarily for use as an attachment for lorry loader cranes. It is designed to be used for re-handling of excavated materials and aggregate. It can be fitted with a number of options:

- > **Additional Bottom Cutting Edges** - can be fitted from new or used for refurbishment purposes
- > **Side Cutting Edges** - can be fitted from new or used for refurbishment purposes. Both cutting edge options come with nut and bolt kits included
- > **Quick Change Hooks** - with safety latches for the attachment of chains and slings
- > **High closing force**
- > **Reinforced bucket shells** to counter damage caused by large objects
- > **High tensile construction**
- > **Fully hardened pins and bushes throughout**
- > **Twist resistant**
- > **Dual compensator bars protected by heavy steel plate**

ROBUST DESIGN AND EFFICIENT HANDLING

The PCM Quick Change hook is designed as an alternative to directly welded on hooks commonly used on lorry mounted re-handling grabs. The benefits of the method of attachment by a specified bolt / fixing kit includes the immediate availability of grabs with or without hooks from stock.

Hooks can easily be retrofitted and hooks can easily be removed.

Damaged hooks can quickly and easily be replaced if damaged without the need for site or workshop welding or area re-painting

Bucket together with different fitting options are available from stock for next day delivery or immediate collection.

The RiteSpec® Grab Bucket is built according to the EC Machinery Directive 89/392 as modified with the EC norms 91/368 and 93/44 and to the European Norm EN 292 1st / 2nd part.

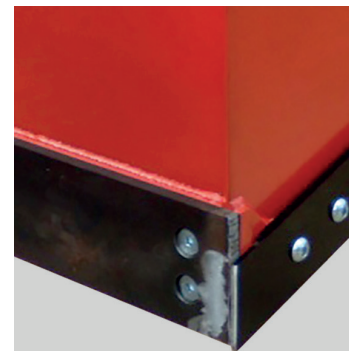

Dimension A	Dimension B	Dimension C	Dimension D	Dimension L
910mm	1250mm	720mm	1750mm	1040mm

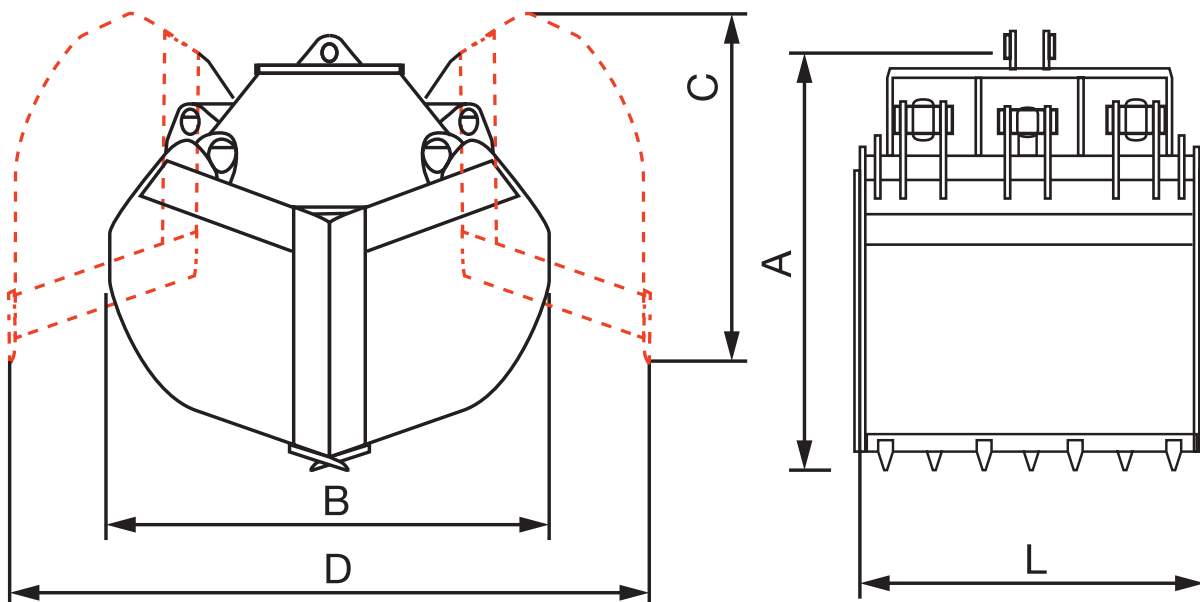

**STALLION PLANT
SERVICES LTD**

Ditchling Common Industrial Estate, Folders Lane East,
Ditchling Common, Hassocks BN6 8SG
T: 01444 246 662 E: info@stallionplant.co.uk

www.stallionplant.co.uk